

WALL BRACKET MOUNTING INSTRUCTIONS

1. Properly secure bracket to wall.
Wall mounting fasteners are not included.
2. Use 1/2-13 hardware as shown in exploded view to secure transformer to brackets.
Torque to 50 ft.lbs. (dry).
This hardware is supplied with kit.

Bracket Material: #10 Ga (.1345" thick)
ASTM A-366 Commercial Quality Steel (C.R.S.)

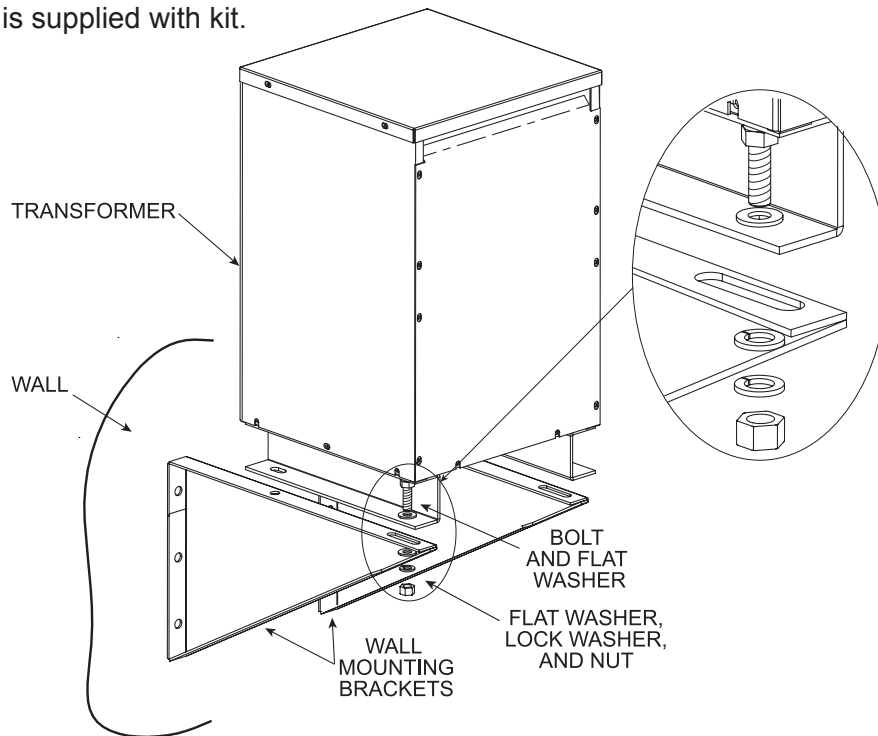

223-7008-030

For use with 15kVA 1- and 3-Phase Transformers

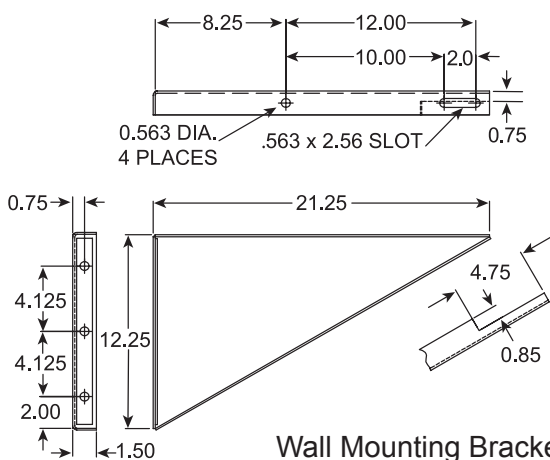

Wall Mounting Bracket
for right and left hand side

223-7008-075

For use with 25 – 75 kVA 1-Phase and
30 – 75 kVA 3-Phase Transformers

